



- Power supply mode: DC 5V
 - DC 12V
 - DC 24V
 - other
- Output form: Switch signal: dry reed switch on and off
 - RS485
 - other
- Instrument line length: Standard configuration: 5 meters
 - Other
- Working temperature: 0~50°C
- Storage temperature: -10°C~50°C
- Product weight: the weight of the bucket is 1700 g, and the total weight is 3300 g

Product introduction

The rain sensor (transmitter) is suitable for relevant departments such as meteorological stations (stations), hydrological stations, agriculture and forestry, and national defense. It is used to remotely measure the amount of liquid precipitation, precipitation intensity, and the start and end time of precipitation. The instrument is produced, assembled and verified in strict accordance with the SL61-2003 Hydrological Automatic Measuring and Reporting System Specification, GB11831-89 Hydrological Measuring and Reporting Device Telemetry Rain Gauge, and GB11832-89 Tipping Bucket Rain Gauge National Standards. It can be used for hydrological automatic forecasting system and automatic field forecasting station for the purpose of flood control, water supply dispatching, water regime management of power station reservoirs, etc.

Technical Parameters

Water bearing diameter: $\Phi 200 \pm 0.6\text{mm}$
 Measuring range: $\leq 4\text{mm/min}$ (precipitation intensity)
 Resolution: 0.2mm (6.28ml)
 Accuracy: $\pm 4\%$ (indoor static test, rain intensity is 2mm/min)

Connection method

- (1) If equipped with a weather station produced by our company, directly use the sensor line to connect the sensor to the corresponding interface on the weather station.
- (2) If the sensor is purchased separately, since the sensor outputs a set of switching signals, the cable connector does not matter whether it is positive or negative. Connect the sensor to the circuit as shown.

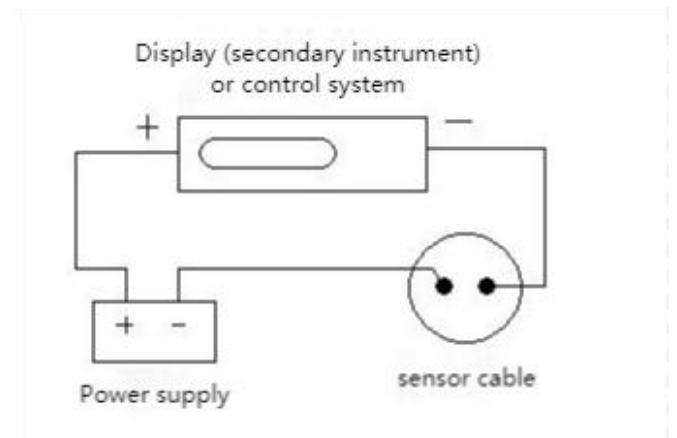

- (3) If the sensor is other signal output, the conventional sensor line sequence and corresponding functions are as follows:

Line color	output signal		
	Current	Voltage	Communication
Red	+	+	+

NBL-W-MRS/Rain sensor

Changsha Zoko Link Technology Co., Ltd.

Blac (Green)	-	-	-
Yellow	Current signal	Voltage signal	A-/TX
Blue			B-/RX

MODBUS-RTU Communication protocol

I Serial Port Format

Data bit 8 bits

1 or 2 stop bits

Check digit None

Baud rate 9600 The interval between two communications is at least 1000ms

II Communication format

【1】 Write device address

Send: 00 10 Address CRC (5 bytes)

Return: 00 10 CRC (4 bytes)

Note: 1. The address bit of the read/write address command must be 00.

2. Address is 1 byte, ranging from 0-255.

Example: send 00 10 01 BD C0

return 00 10 00 7C

【2】 Read device address

Send: 00 20 CRC (4 bytes)

Return: 00 20 Address CRC (5 bytes)

Description: Address is 1 byte, the range is 0-255

Example: Send 00 20 00 68

return 00 20 01 A9 C0

【3】 Read real-time data

Send: Address 03 00 00 00 01 XX XX

Description: As shown in the figure below:

CODE	Functional Definition	Remark
Address	Station number (address)	
03	Function code	
00 00	Start address	
00 01	Read points	
XX XX	CRC Check code, low front and high back	

Return: Address 03 02 XX XX XX XX

Description:

CODE	Functional Definition	Remark
Address	Station number (address)	
03	Function code	
02	Read unit bytes	
XX XX	Date (low front and high back)	Hex
XX XX	CRC Check code	

Steps to calculate CRC code:

1. The preset 16-bit register is hexadecimal FFFF (that is, all 1). Call this register the CRC register;
2. XOR the first 8-bit data with the low bit of the 16-bit CRC register, and put the result in the CRC register;
3. Shift the content of the register to the right by one bit (towards the lower bit), fill the highest bit with 0, and check the lowest bit;
4. If the lowest bit is 0: repeat step 3 (shift again)
If the lowest bit is 1: XOR the CRC register with the polynomial A001 (1010 0000 0000 0001);
5. Repeat steps 3 and 4 until the right shift is 8 times, so that the entire 8-bit data has been processed;
6. Repeat steps 2 to 5 to process the next 8-bit data;
7. The final CRC register is the CRC code;
8. When putting the CRC result into the information frame, exchange the high and low bits, with the low bits first.

RS485 Circuit

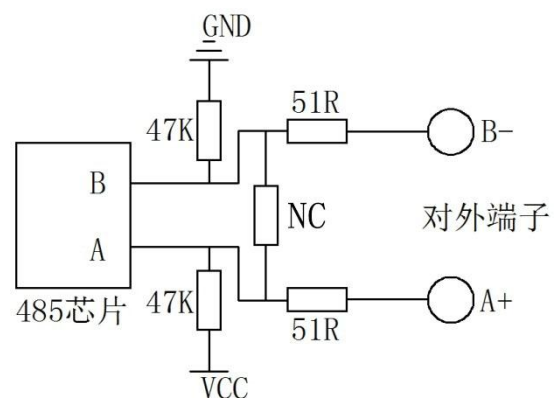

Installation

1. The installation position of the sensor can be selected according to the actual requirements on the ground, a self-made large cylinder, an iron column flange or the roof of the house;
2. Adjust the three leveling screws on the chassis to make the level indicated by the level bubble (the bubble stays in the center of the circle), and then slowly tighten the three M8 × 80 fixed expansion screws; if the level bubble changes, it needs to be readjusted ;
3. As shown in the above figure, assemble and fix the sensor;
4. After fixing, open the rain gauge barrel, cut off the nylon cable tie on the funnel, slowly pour clean water into the rain gauge sensor, and observe the turning process of the tipping bucket to check whether the data is received on the acquisition instrument. Finally, inject quantitative water (60-70mm). If the data displayed by the acquisition instrument is consistent with the injected water volume, it means that the instrument is normal, otherwise it needs to be repaired and adjusted;
5. Please avoid disassembling the sensor during installation.

Notice

1. Please check whether the packaging is in good condition, and check whether the product model is consistent with the selected model;
2. Do not connect live wires, and power on after the wiring is completed and checked;
3. The length of the sensor wire will affect the output signal of the product. When using it, do not change the components or wires that have been welded when the product leaves the factory. If you need to change it, please contact the manufacturer;
4. The sensor should be checked regularly to remove dust, mud, sand, leaves, and insects, so as not to block the water flow channel of

the upper cylinder (funnel). The cylindrical filter can be removed and rinsed with clean water;

5. If there is dirt on the inner wall of the tipping bucket, it can be washed with water or alcohol or detergent solution. It is strictly forbidden to wipe it with fingers or other objects, so as not to be stained with oil or scratch the inner wall of the tipping bucket;
6. During the freezing period in winter, the instrument should be stopped and taken back indoors;
7. Please keep the verification certificate and certificate of conformity, and return it with the product when repairing.

Trouble Clearing

1. The display instrument has no indication value. The collector may not be able to obtain information correctly due to wiring problems. Please check whether the wiring is correct and firm;
2. The value indicated by the display is obviously inconsistent with the actual situation. Please empty the water in the bucket and re-inject a certain amount of water (60-70mm) into the bucket, and clean the inner wall of the tipping bucket;
3. If it is not the above reasons, please contact the manufacturer.

Contact us

Pre-sales consultation: +8618073152920

Email:sales@niubol.com

Postcode: 421000

Website: <http://www.niubol.com>

Address: Room 103, Zone D, Houhu Industrial Park, Yuelu District, Changsha City, Hunan Province,China